

TECHNICAL DESCRIPTION TD-30

The Rockwheel TD-30 Hydraulic Cutting Unit can be supplied with either scaling/grinding cutting drums or rock cutting drums.
For advice re different diameters, widths and/ or picks contact Webster Equipment Ltd Technical Department.



TD-30 Specification

Maximum Input Power	- 22 kW	- 29.5 hp
Maximum Flow	- 65.0 lpm	- 14.5 UK gpm
Recommended Flow	- 40.0 lpm	- 8.8 UK gpm
Maximum Pressure	- 400 bar	- 5,801 psi
Output Shaft Torque	- 1,875 Nm @ 300 bar	- 1,383 lbf ft @ 4,351 psi
Pick Force	- 9.9 kN @ 300 bar	- 2,229 lbf @ 4,351 psi
Output Shaft Speed	- 100.0 rpm @ 40 lpm	- 100.0 rpm @ 8.8 UK gpm
Pick Speed	- 1.98 m/s @ 40 lpm	- 460.5 ft/min @ 8.8 UK gpm
Unit Weight	- 215 kg	- 474 lb
Excavator Range	- 2.5 – 6.0 tonne	- 2.0 – 6.0 tonne
No of Picks (Rock Drums)	- 56 (19.0 mm Shank)	- 56 (0.76" Shank)

If oil specification is below 46 centistokes at 40°C (ISO HV46) the performance must be down rated.
Please consult Webster Equipment Technical Department for further information.

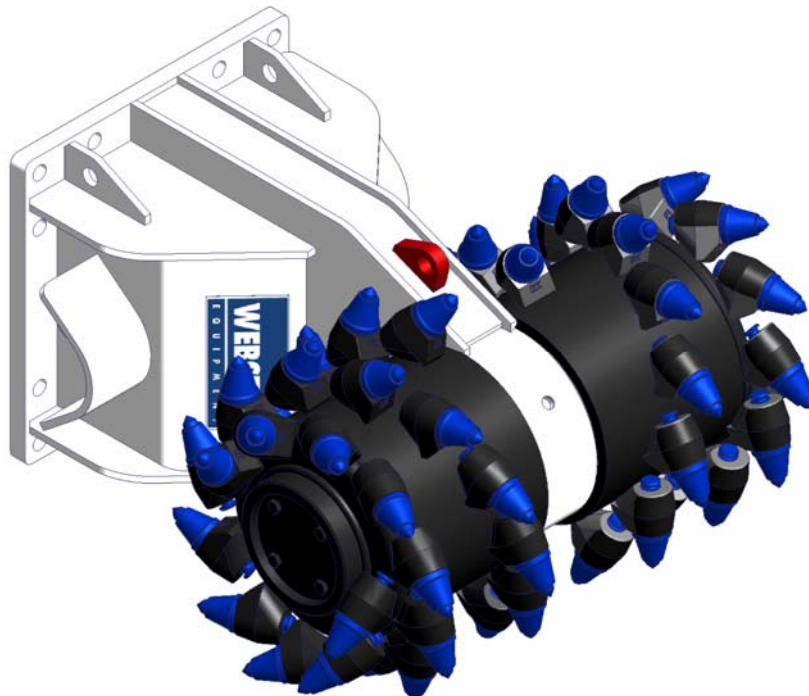

To simplify installation the Rockwheel TD-30 mounting flange is designed to suit existing hydraulic breakers.

